

ICA H & S Strain Gauge or Load Cell Embedded Analogue Amplifiers

User Manual
mantracourt.com

ME mantracourt

ICA H & S Manual

Contents

Chapter 1 The ICA H & S Range	2
Figure 1.1 Block Diagram.....	2
Chapter 2 Installing the ICA H & S Range	3
Pre Installation.....	3
Figure 2.1 Dimensions.....	3
ICA1H & ICA2H Connections.....	4
Figure 2.2 Connection Details for the ICA1H & ICA2H.....	4
Figure 2.3 Connection Details for Best EMC Immunity.....	4
ICA3H & ICA6H Connections.....	5
Figure 2.4 Connection Details for the ICA3H.....	5
Figure 2.5 Connection Details for the ICA6H.....	5
Figure 2.6 Connection Details for Best EMC Immunity.....	5
ICA4H Connections.....	6
Figure 2.7 Connection Details for the ICA4H - Source mode.....	6
Figure 2.8 Connection Details for the ICA4H - Sink mode.....	6
Figure 2.9 Connection Details for Best EMC Immunity.....	6
ICA5S & ICA5A Connections.....	7
Figure 2.10 Connection Details ICA5S & ICA5A.....	7
Figure 2.11 Connection Details for Best EMC Immunity.....	7
Output Connections.....	8
Output Shunt Resistance Formula.....	8
Table 2.1 - The ICA H & S Cable Data.....	8
Chapter 3: Calculating the Gain Resistor Values	9
ICA1H & ICA2H.....	9
Table 3.1 ICA1H (0.1 V to 10.1 V) Gain Resistor Formula.....	9
Table 3.2 ICA2H (0.1V to 5.1V) Gain Resistor Formula.....	9
Table 3.3 ICA1H & ICA2H Offset Resistor Formula.....	9
ICA3H & ICA6H.....	10
Table 3.4 ICA3H & ICA6H (± 10 Volts) Gain Resistor Formula.....	10
ICA4H.....	10
Table 3.5 ICA4H.....	11
ICA5S & ICA5A.....	12
ICA5S & 5A Offset Resistor (R1).....	12
Chapter 4 Calibration	13
Figure 4.1 Connection Details for Calibration.....	13
Chapter 5 Trouble Shooting	14
Chapter 6 Product Care	15
Chapter 7 Glossary	16
Chapter 8 Specifications for the ICAH Range	18
Table 8.1 ICA1H (0.1 to 10.1 V).....	18
Table 8.2 ICA2H (0.1 to 5.1 V).....	19
Table 8.3 ICA3H (± 10 V).....	20
Table 8.4 ICA4H (4 to 20 mA).....	21
Table 8.5 ICA5S (2-wire 4-20 mA).....	22
Table 8.6 ICA5A (2-wire 4-20 mA).....	23
Table 8.7 ICA6H (± 10 V).....	24

Chapter 1 The ICA H & S Range

Figure 1.1 Block Diagram

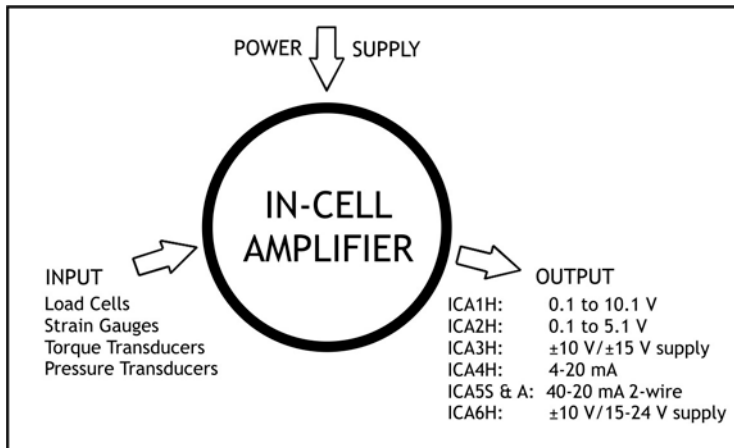

The ICA is a Strain Gauge Amplifier, converting a strain gauge input to a Volt or mA output - otherwise known as a Signal Conditioner.

The ICA provides a wide range of signal conditioning for Strain Gauges, Load Cells, Pressure and Torque Transducers.

Offered in 5 Very High Stability versions:

- ICA1H 3 wire - 0.1 to 10.1 V
- ICA2H 3 wire - 0.1 to 5.1 V
- ICA3H 4 wire - ± 10 V / ± 15 V supply
- ICA4H 3 wire - 4 to 20 mA
- ICA6H 3 wire - ± 10 V / 15-24 V supply

Industrial Stability versions:

- ICA5 S & A 2 wire - 4 to 20mA

N.B. The ICA5 is designed for a 1000 Ohm bridge or higher, however 350 Ohms *can* be used but with reduced performance (see Chapter 3 'ICA5S & ICA5A')

Transducer **SENSITIVITY** of between 0.5 mV/V and greater than 10 mV/V are possible. As supplied they are optimised to 2.5 mV/V. This range covers most, but not all strain gauges.

Sensitivity adjustment (**SPAN**) is achieved by a combination of gain (span) resistor 'R' change and associated *fine adjustment* by potentiometer.

Similarly transducer **ZERO** can be compensated for in the module. This adjustment is to compensate for slight errors in the strain gauge and not to offset tare.

The ICA6H

The ICA6H is a two-part module which combines an ICA3H with a DC-DC power module.

The power module generates both positive and negative supply rails for the ICA3H thereby enabling it to produce its normal ± 10 V output from a single 15-24 V supply.

The ICA6H also has pads on its underside which can be used to mount and provide connections for a range of Transducer Electronic Data Sheet ICs (TEDS).

Chapter 2 Installing the ICA H & S Range

Pre Installation

See Specification details in Chapter 8 for details of Environmental Approvals.

Carefully remove the ICA unit from its shipment box. Check that the unit is complete and undamaged.

The ICA units can be operated in any industrial environment providing the following limits are not exceeded.

Operating Temperature	-40°C to +85°C
Humidity	95% non condensing
Storage temperature	-40°C to +85°C

The following installation practices are advised:

- Minimise vibration
- Do not mount next to strong electrical fields (transformers, power cables)
- Ensure easy access to the module
- Install electrical protection device as the unit is not internally fused - a short across the excitation terminals could cause permanent damage
- Always ensure the package is secure and protected

Figure 2.1 Dimensions



The module is designed to fit in the strain gauge pocket. Use the 2.1mm hole to secure the unit.

The mounting hole will accept an M2 screw or American equivalent #0-80.

Important Note: DO NOT USE #2 screw size.

Take care when soldering cables to the pads.

Use a temperature controlled soldering iron set to a maximum 330 °C, for no longer than 2 seconds per pad.

Excessive heat or increased soldering time may result in damage to the PCB.

If changing the gain resistor 'R' do so at a workbench and not on site.

The ICAH solder pads are as shown in the wiring diagrams:

4 pads for the strain gauge.

Power supply and output pads

2 pads for sink or source option (ICA4H only)

The fixing screw hole provides a ground connection to improve EMC performance.

ICA1H & ICA2H Connections

The power supply for the ICA1H is nominally 24 V dc (between 13 and 28 V) and ICA2H is nominally 12 V dc (between 8.5 and 28 V). The power supply is commoned with the output at the 'com' connection.

Figure 2.2 Connection Details for the ICA1H & ICA2H

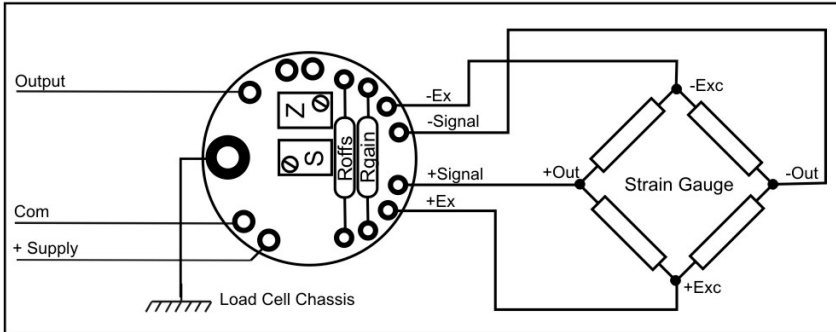

The strain gauge cable should be attached to the solder pads as illustrated. For most applications 3 wire un-shielded field wiring is quite adequate. For best EMC performance use the connections shown in Figure 2.3

Figure 2.3 Connection Details for Best EMC Immunity

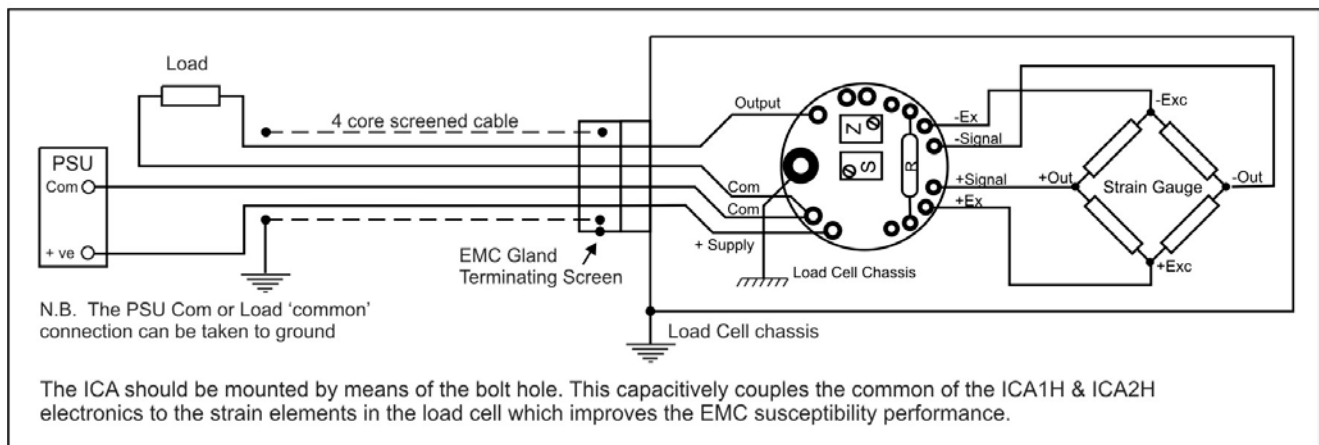

Take note of the grounding arrangement particularly the bolt hole which capacitively couples the common of the ICAH electronics to the strain elements in the load cell which improves the EMC performance.

ICA3H & ICA6H Connections

The ICA3H requires a $\pm 14\text{V}$ bipolar dc power supply within the limits of $\pm 13\text{ V}$ to $\pm 15\text{ V}$.

The ICA6H requires a 15 to 24 V uni-polar dc power supply. Ideally this should be limited to +15 V to +18 V for 350 Ohm load cells to minimise the on-board temperature rise thereby reducing any warm-up time.

In both cases the power supply is commoned with the output at the 'Com' connection.

Figure 2.4 Connection Details for the ICA3H

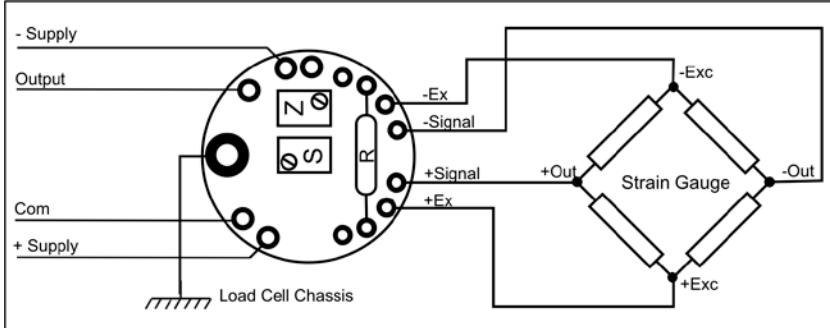

The strain gauge cable should be attached to the solder pads as illustrated. For most applications 3 wire un-shielded connections for field wiring is quite adequate.

For best EMC performance use the connections shown in Figure 2.4

Figure 2.5 Connection Details for the ICA6H

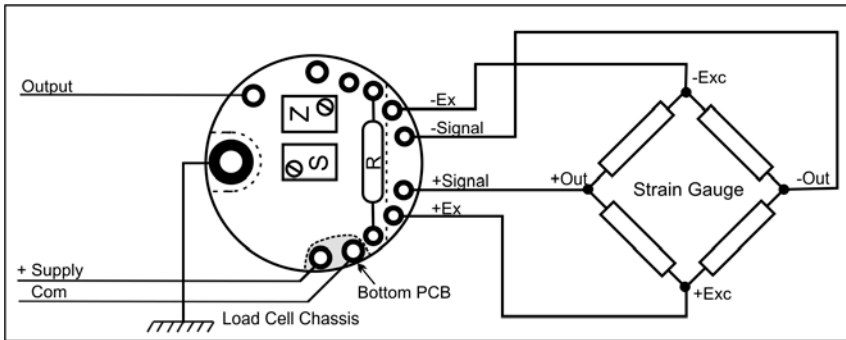

The power supply connections for the ICA6H are located on the bottom PCB.

In the following connection diagrams the '-Supply' connection can be ignored for the ICA6H.

Figure 2.6 Connection Details for Best EMC Immunity

See Figure 2.3 for ICA6H power connections.

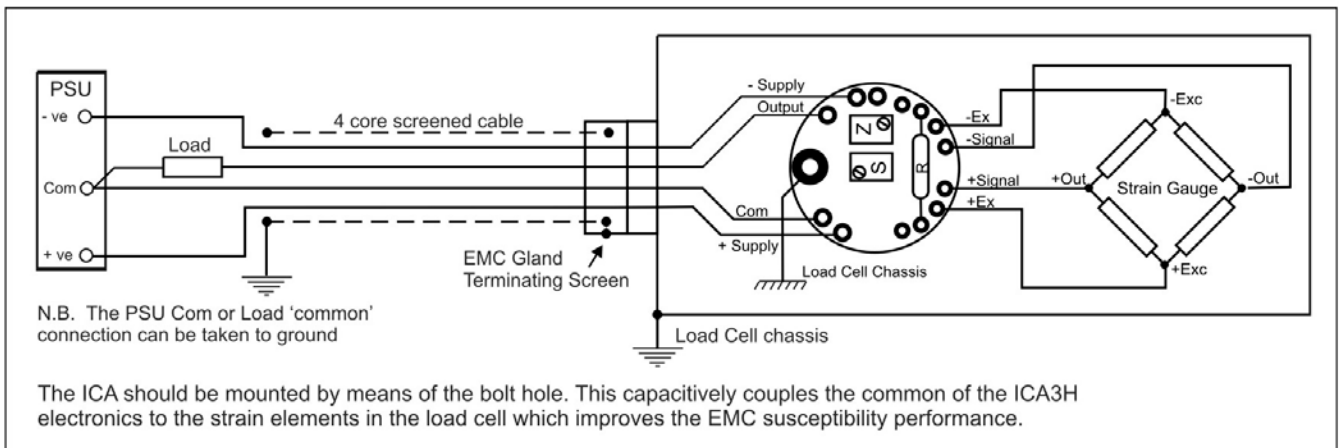

Take note of the grounding arrangement particularly the bolt hole which capacitively couples the common of the ICA electronics to the strain elements in the load cell which improves the EMC performance.

ICA4H Connections

The power supply for the ICA4H is 24 V dc (within the limits of 13 V to 28 V).

Figure 2.7 Connection Details for the ICA4H - Source mode

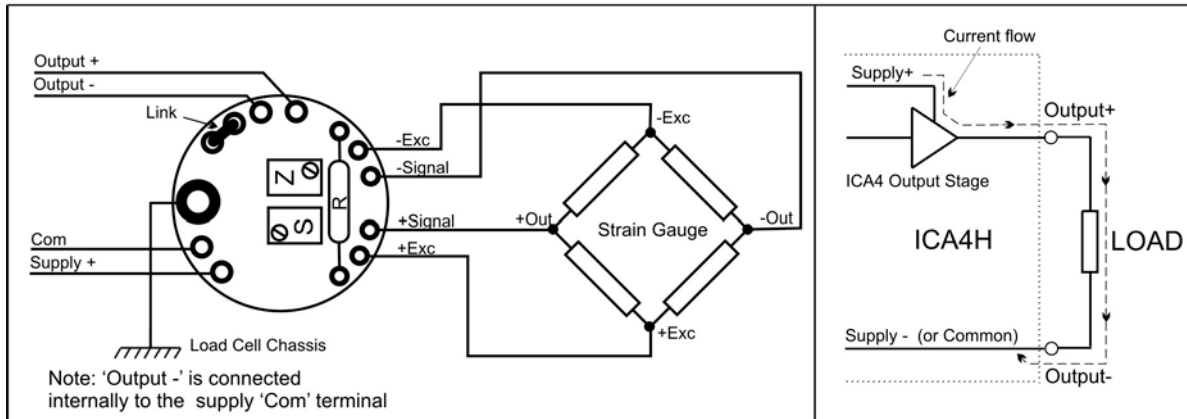

Figure 2.8 Connection Details for the ICA4H - Sink mode

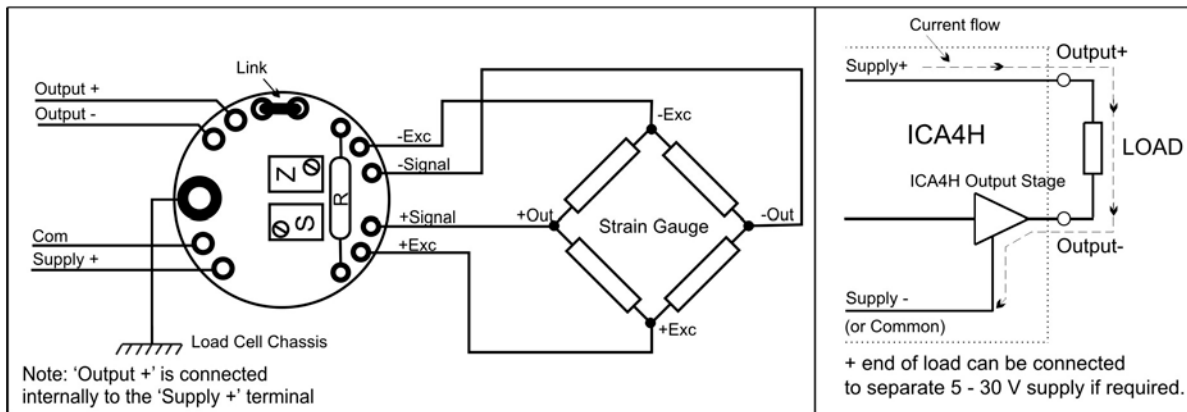
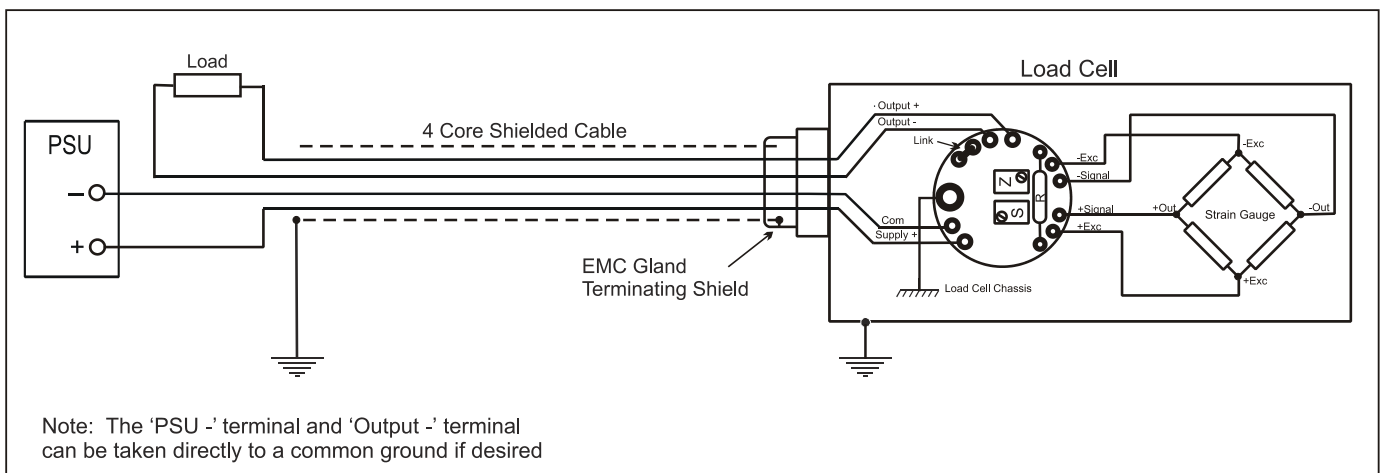

Figure 2.9 Connection Details for Best EMC Immunity



Take note of the grounding arrangement particularly the bolt hole which capacitively couples the common of the ICA electronics to the strain elements in the load cell which improves the EMC performance.

The ICA4H can be used with three wire cabling in both sink and source mode. The only difference between the two modes is whether the common end of the load is connected to the positive of the PSU (sink mode) or the negative of the PSU (source mode).

ICA5S & ICA5A Connections

The power supply for the ICA5S should be between 7.5 and 28 V
 The minimum supply for the ICA5A version is 9 V

Please note that by design, the excitation voltage provided by a 2-wire load cell amplifier decreases as the load cell's impedance decreases resulting in a reduction in the load cell's output. The lower signal level requires more gain from the ICA5 to compensate leading to a degradation in performance with regard to temperature stability and noise performance.

Impedances greater than 1000 Ohms and sensitivities of 1mV/V and higher are recommended.

Figure 2.10 Connection Details ICA5S & ICA5A

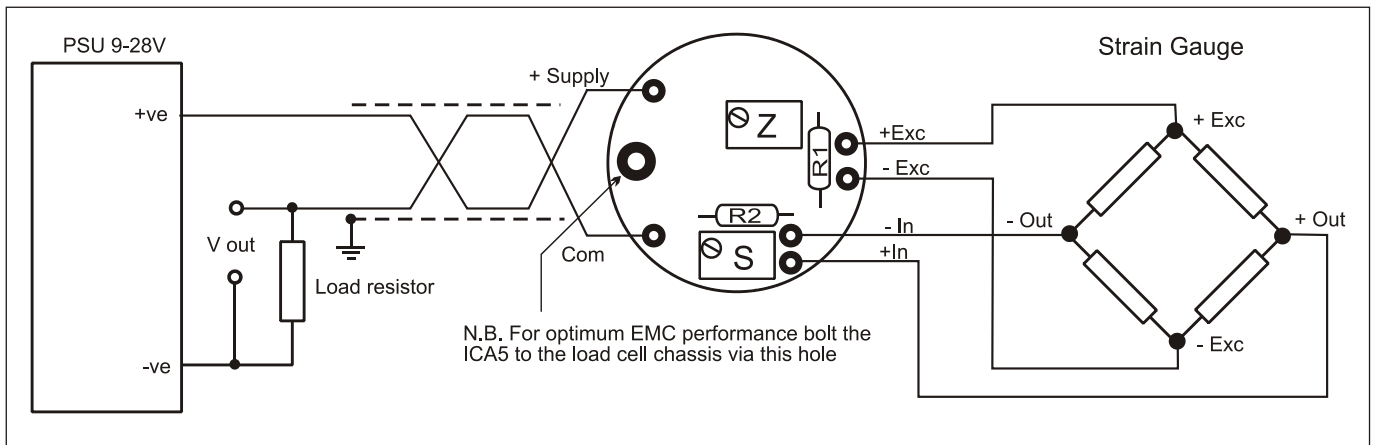

The strain gauge cable should be attached to the solder pads as illustrated.

N.B The voltage between either of the power supply connections and the load cell chassis should not exceed 50 V. Any leakage will be greater than 10 M Ohms.

Figure 2.11 Connection Details for Best EMC Immunity

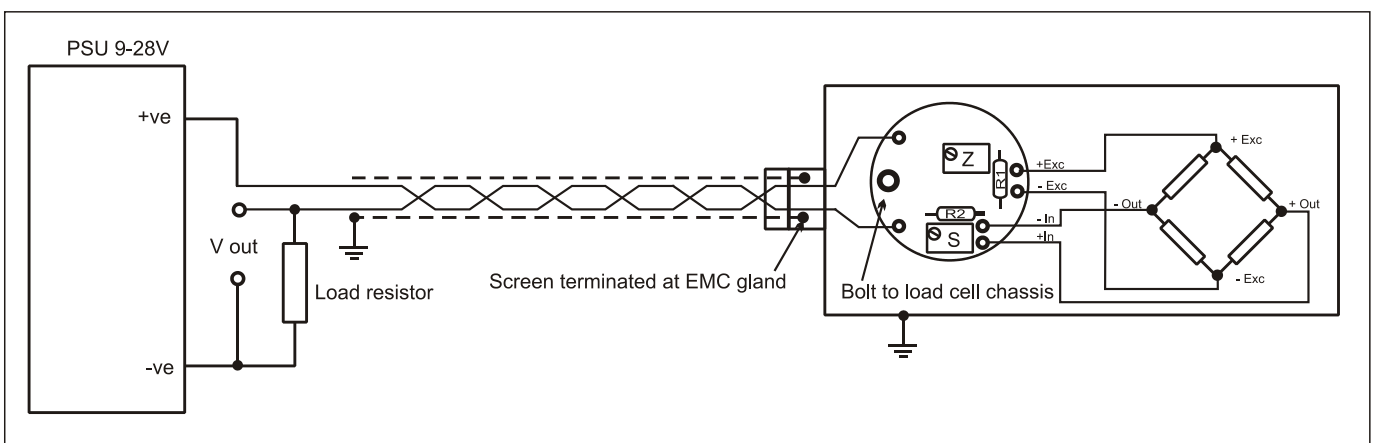

The securing bolt should be used to provide a good electrical ground and mechanical support. This is important for optimum EMC performance.

Output Connections

The ICA5 analogue output is 4 to 20 mA. The power and signal are combined in a single pair cable, simplifying installation.

N.B. Neither connection to the output load is electrically common to the load cell.

The following formula gives the suitable range of shunt resistance for low supply voltage operation.

Output Shunt Resistance Formula

ICA5S: the shunt resistance must be less than:

$$((V_{\text{supply}} - 7.5) / 20 \text{ mA}) - R_{\text{wiring}}$$

e.g. assuming 10 Ohms wiring resistance and 9 V supply:

$$\text{Max shunt resistance} = ((9 - 7.5) / 0.02) - 10 = 65 \text{ Ohms}$$

ICA5A: the shunt resistance must be less than:

$$((V_{\text{supply}} - 9) / 20 \text{ mA}) - R_{\text{wiring}}$$

Table 2.1 - The ICA H & S Cable Data

This typical cable data is provided for information only.

The cable should have 2 x twin twisted cables. Ideally each pair should be individually shielded and with an overall shield.

Country	Supplier	Part No	Description
UK	Farnell	118-2117	Individually shielded twisted multi-pair cable (7/0.25mm)- 2 pair Tinned copper drain. Individually shielded in polyester tape. Diameter: 4.1mm Capacitance/m: core to core 115 pF & core to shield 203 pF
UK	Farnell	585-646	Individually shielded twisted multi-pair cable (7/0.25mm)- 3 pair Tinned copper drain. Individually shielded in polyester tape. Diameter: 8.1mm Capacitance/m: core to core 98 pF & core to shield 180 pF
UK	RS	749-2591	Braided shielded twisted multi-pair cable (7/0.2mm)- 1 pair Miniature- twin -round Diameter: 5.2 mm Capacitance/m: core to core 230 pF & core to shield 80 pF

If possible segregate the signal cable from Power Cables; allow a 1metre (3 feet) distance from such cables.

Do not run signal cables in parallel with power cables and cross such cables at right angles.

The ground connection conductor should have sufficient cross-sectional area to ensure a low impedance path to attenuate RF interference.

Chapter 3 Calculating the Gain Resistor Values

ICA1H & ICA2H

The ICA1H and 2H are supplied un-calibrated but optimized for a sensitivity of 2.5mV/V. To accommodate other sensitivities the gain resistor 'Rgain' shown in Figure 2.2, can be changed according to the following formula. N.B. a high quality component e.g. 1% 10-15 ppm/°C metal film resistor should be used for optimum performance. It may be necessary to use a value from the less common E96 series to optimise the trim range:-

Table 3.1 ICA1H (0.1 V to 10.1 V) Gain Resistor Formula

Gain	=	$\frac{372}{(\text{required mV/V})}$	Rgain	=	$\frac{40,000}{(\text{Gain}-1)}$ Ohms
e.g. 1	For 2.5 mV/V (Factory setting):-	Gain = 149 x	R= 270 Ohms	(Use preferred value 270R)	
e.g. 2	For 0.5 mV/V	Gain = 744 x	R= 53.8 Ohms	(Use preferred value 53.6R - E96 series)	

Table 3.2 ICA2H (0.1V to 5.1V) Gain Resistor Formula

Gain	=	$\frac{186}{(\text{required mV/V})}$	Rgain	=	$\frac{40,000}{(\text{Gain}-1)}$ Ohms
e.g. 1	For 2.5 mV/V (Factory setting):-	Gain = 74.4 x	R= 545 Ohms	(Use preferred value 549R - E96 series)	
e.g. 3	For 5.0 mV/V	Gain = 37.2 x	R= 1105 Ohms	(Use preferred value 1K1)	

Table 3.3 ICA1H & ICA2H Offset Resistor Formula

The ICA1H and 2H can be used in a pseudo 'bipolar' mode by fitting a resistor 'Roffs' as shown in Figure 2.2. This will shift the output voltage to a known level (Voffs) when the input is zero (0mV/V) allowing both tension and compression of the load cell to be measured.

Use the following formula for the ICA1H & ICA2H to calculate the value of Roffs in k Ohms:

Roffs	=	$\frac{148 \text{ k}}{(\text{Voffs} - 0.1)}$
e.g. for 2.5V offset (bipolar ICA2)		
Roffs	=	$\frac{148 \text{ k}}{(2.5 - 0.1)} = \frac{148 \text{ k}}{2.4} = 61.7 \text{ k Ohms}$ (Use preferred value 61.9 k - E96 series)
e.g. for 5.0V offset (bipolar ICA1)		
Roffs	=	$\frac{148 \text{ k}}{(5.0 - 0.1)} = \frac{148 \text{ k}}{4.9} = 30.2 \text{ k Ohms}$ (Use preferred value 30 k)

The gain of the ICAH will need to be reduced to account for the lower output swing required for a given input change.

For the ICA1H, re-calculate Rgain by scaling the load cell's mV/V by the ratio 10 V/(bipolar output change) and 5 V/(bipolar output change) for the ICA2H and use the above formulae.

For example, an ICA2H is required to operate at 2.5 V ±2.4 V for a ± 2.5 mV/V input:

Fit Roffs = 61.7 k (as above) and re-calculate Rgain from Table 3.2 using (5 V/2.4 V) x 2.5m V/V = 5.208m V/V

i.e. Gain = 35.71 therefore Rgain = 1152 Ohms. The nearest preferred value is 1k15 (E96 series).

ICA3H & ICA6H

The ICA3H & ICA6H are ± 10 V Strain Gauge Amplifiers.

They are supplied un-calibrated but optimized for a sensitivity of 2.5 mV/V. To accommodate other sensitivities the gain resistor 'R' as shown in Figure 2.2, can be changed according to the following formula.

N.B. a high quality component e.g. 1% 15-25 ppm/°C metal film resistor should be used for optimum performance. It may be necessary to use an E96 value to optimise the trim range:-

Table 3.4 ICA3H & ICA6H (±10 Volts) Gain Resistor Formula

Gain	=	$\frac{372}{(\text{required mV/V})}$		R	=	$\frac{40,000}{(\text{Gain}-1)}$	Ohms
e.g. 1		For 2.5 mV/V (Factory setting):-	Gain = 149 x	R= 270 Ohms			(Use preferred value 270 R)
e.g. 2		For 0.5 mV/V	Gain = 744 x	R= 53.8 Ohms			(Use preferred value 53.6 R E96)
e.g. 3		For 5.0 mV/V	Gain = 74.4 x	R= 545 Ohms			(Use preferred value 549 R E96)

N.B If an output other than ± 10 V is required e.g. ±5V then reduce the gain calculation in proportion i.e. for ±5 Volt

Gain	=	$\frac{372}{(\text{required mV/V})}$	x	$\frac{5}{10}$		R	=	$\frac{40,000}{(\text{Gain}-1)}$	Ohms
e.g.1		For 2.5 mV/V (Factory setting):-	Gain =	74.4 x		R = 545 Ohms			(Use preferred value 549R E96)

ICA4H

The ICA4H In-Cell strain gauge amplifier is supplied un-calibrated but optimised for a sensitivity of 2.5 mV/V. To accommodate other sensitivities the gain resistor 'R' must be fitted (see Figure 2.2). The value of R is calculated using the formulae below.

N.B. a high quality component e.g. 1% 25 ppm metal film resistor should be used for optimum performance use 10-15 ppm metal film devices to maintain their temperature drift performance. It may be necessary to use an E96 value to optimise the trim range.

Use the appropriate formula below depending on whether the ICA4H needs to be adjusted for a higher or lower mV/V sensitivity.

N.B. The ICA4H gain resistor comprises two surface mount gain resistors instead of the leaded type (see diagram). To configure the amplifier to suit a load cell higher than 2.5mV/V these must be removed and formula 3.2 used to calculate the value of 'R'.

Use formula 3.1 to suit load cells less than 2.5mV/V.

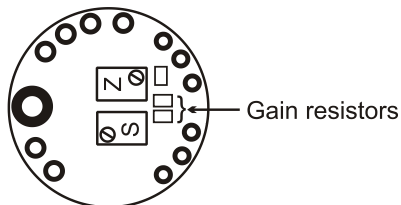

Table 3.5 ICA4H

Formula 3.1: To set the mV/V figure LOWER than 2.5 (increase the gain)

To match a LOWER mV/V setting, use the following formulae:

$$Gain = \left(\frac{160}{\text{required mV/V}} \right) \quad R_x = \left(\frac{63,200}{(Gain - 1)} \right) \text{ Ohms} \quad R = \left(\frac{1}{\left(\frac{1}{R_x} - 0.001 \right)} \right) \text{ Ohms}$$

e.g. for 2.0mV/V Gain = 80 R = 4000 Ohms (use preferred value 3 k9 or 4k02 (E96))

Formula 3.2 To set the mV/V figure HIGHER than 2.5 (decrease the gain)

If the gain of the ICA4H needs to be reduced i.e. to match a HIGHER mV/V setting then the two surface mount gain resistors shown above must be removed and the following formulae used to calculate the new value for the gain resistor:

$$Gain = \left(\frac{160}{\text{required mV/V}} \right) \quad R = \left(\frac{63,200}{(Gain - 1)} \right) \text{ Ohms}$$

e.g. for 5.0mV/V Gain = 32 R = 2039 Ohms (use preferred value 2 k or 2k05 (E96))

The new gain resistor should be fitted in position 'R' as shown in Figure 2.2

ICA5S & ICA5A

The ICA5S & ICA5A (2-wire 4 - 20 mA) In-Cell strain gauge amplifiers are supplied un-calibrated but optimized for a sensitivity of 2.5 mV/V. To accommodate other sensitivities the gain resistor 'R2' as shown in Figure 2.10, can be changed according to the following formulae. Load cells with less than 1mV/V sensitivity are not recommended.

N.B. a high quality, <50 ppm/°C 1% metal film resistor should be used for optimum performance. It may be necessary to use an E96 value to optimise the trim range.

Table 3.6 ICA5S & ICA5A (±10 Volts) Gain Resistor Formula

$$R2 = \left(\left(\frac{613.6}{mV/V \times V_{exc}} \right) \times \left(\frac{Z + 20000}{20000} \right) - 10 \right) \text{ k Ohms}$$

Where mV/V is the sensitivity of the load cell (in mV/V), V_{exc} is the excitation voltage (in Volts) and Z is the load cell impedance (in Ohms).

e.g. For a 2.5 mV/V 1000 Ohm load cell : $R2 = 228.6 \text{ k Ohms}$ - use 220 k (nearest E24 preferred value) or 229 k (nearest E192 preferred value)

The following table gives calculated values of V_{exc} for various standard load cell impedances:

Load Cell Impedance	Excitation voltage (V exc)
350	0.53
700	0.87
1000	1.08
1400	1.29
2000	1.51
5000	1.97

Use the following formulae to calculate the excitation voltage for cell impedances not given in the table:

$$R_x = \left(\frac{1}{(1/R_{cell}) + 4.762 \times 10^{-6}} \right) \text{ Ohms}$$

$$V_{exc} = \left(\frac{2.5 \times R_x}{R_x + 1300} \right) \text{ Volts}$$

e.g. for a 500 Ohm load cell:

$R_x = 498.8 \text{ Ohms}$

Excitation Voltage, $V_{exc} = 0.693 \text{ V}$

ICA5S & 5A Offset Resistor (R1)

The value of R1 can be changed to offset the zero point if it is outside the normal trimming range ($\pm 2\%$ FS). Its value will also depend on the impedance of the load cell. The factory-fitted value, 180k is optimised for a 1000 Ohm cell.

Chapter 4 Calibration

The ICA amplifiers can be calibrated with the transducer connected provided that two calibration points can be implemented e.g. by applying known weights or forces. If this is not possible, a stable mV source or load cell simulator can be used if the precise sensitivity (mV/V) of the transducer is known.

Figure 4.1 Connection Details for Calibration

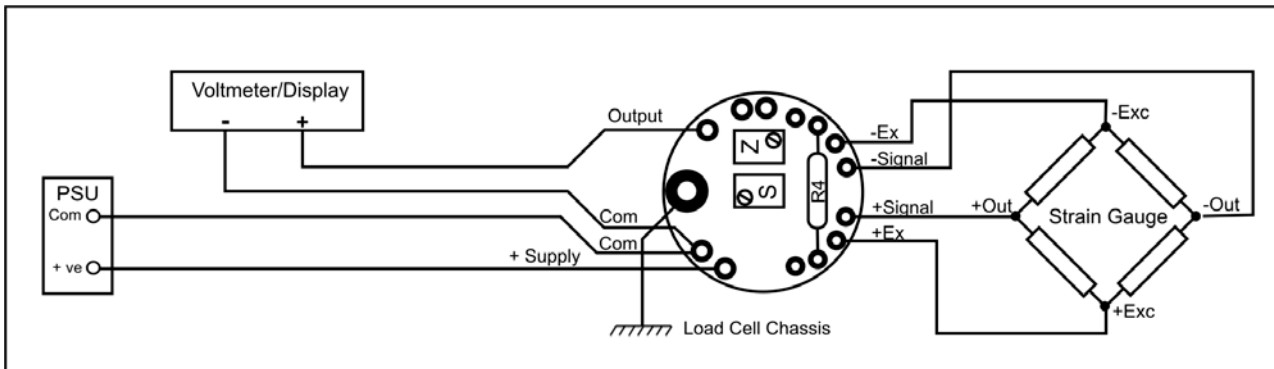

1. Apply the known **low** calibration conditions (weight, force or mV/V). This may be zero if required, and using the 'Z' potentiometer, set the output to the relevant low level depending on the model e.g. 0.1 V for the ICA1H, 4mA for the ICA4H etc.
2. Apply the known **high** calibration conditions (ideally between 75% and full scale) and adjust the 'S' potentiometer to set the output to the relevant high level depending on the model e.g. 5.1 V for the ICA2H at full scale, 20 mA for the ICA4H etc.
3. Apply the known **low** calibration conditions and re-adjust the Zero if required

Chapter 5 Trouble Shooting

1. No Output

- a) Check power supply is present and the correct polarity
- b) Check the output connections are correct with no open circuit connections
- c) Check terminations (ensure there are no dry joints)
- d) Check the sensor is connected (typically reading 350 Ohm across output + & -) with the power off
- e) Check the Excitation voltage is correct
- f) Check the load is connected and is not open or short circuited
- g) Check Span and Gain calibration

2. Low Output

This is when an output is present but not of sufficient magnitude to meet the required value. Remember to allow for Tare Weight and ensure it is measured and allowed for in the output from the ICA.

- a) Check power supply is within specified limits (i.e. is not low)
- b) Check the sensor is connected (typically reading 350 Ohm across output + & -) with the power off
- c) Check the Excitation voltage is at 5 V dc for the ICA1-4H & ICA6H (see Table 3.6 for ICA5S & ICA5A)
- d) Check the calibration
- e) Check the Zero (offset) is correct for the sensor, this too is a common reason for low outputs

3. High Output

This is when an output is present but higher (in span or zero) than expected.

High output is not normally a problem. It is most likely to be incorrect connections and as such the output would be high and fixed

- a) Check the sensor is connected (typically reading 350 Ohm across output + & -) with the power off
- b) Check the Excitation voltage is at 5V dc for the ICA1-4H and 6H (see Table 3.6 for ICA5S & ICA5A)
- c) Check the Zero (offset)
- d) Check the calibration

4. Unstable Output

This is when the output is unstable or varies. The cause could be (a) poor installation or (b) a noisy environment.

Poor Installation - This is when an output is present but higher or lower (in span or zero) than expected:

- a) Check the installation for problems and repair where necessary
- b) Poor termination
- c) High resistance on cable leads
- d) Low insulation impedance
- e) Proximity to High Voltage Equipment - Transformers, Contactors, Motors etc.

Noisy Environment -

- a) Check if the source can be found and remove noise
- b) Check the cable shielding and ensure it is correctly installed and terminated

5. Calibration

This section assumes that the unit is providing an output that is not stuck at top or bottom of the scale.

(See paragraphs 1-3 if this is the case)

Ensure you are connected to the correct sensor and not to another adjacent unit.

Ensure you have the correct calibration data from the sensor manufacturer. This must include a certified table with offset, zero and linearity.

Ensure you have the calibration set-up correctly installed i.e. mV source and output as required.

Ensure the temperature and other environmental parameters are within specification and where necessary taken into account when calibrating should such parameters have an effect on the calibration.

6. Fine Span (Gain) and Zero (Offset) Adjustment Problems

If the adjustment cannot reach the maximum output desired then, check the tare is not too high.

If the potentiometer does not alter the output the unit must be repaired - remove from service.

It is always wise to check a known good ICA against the problem installation before rejecting the suspect ICA.

Chapter 6 Product Care

A worn out component, excessive use in harsh environments, an overly zealous operator; regrettably some circumstances necessitate repair.

At Mantracourt Electronics Ltd we can't guarantee that a product will never require repairing. We can, however, promise a repair service of exceptional quality, one which is governed by a rigorous procedure.

Detailed below is our pledge to you: a defined set of ground rules and procedures to which we will adhere. All we ask in return is that you assist us with our procedure, such that we can maintain our promise to you. Please note that warranty repairs may not be available on overdue accounts, and that a strict interpretation of our conditions of trading invalidates warranty claims where late payment has occurred.

Please refer to the RMA Form - (Return Material Authorization), contact your distributor for a copy.

In the unlikely event you have problems with the ICA module we would advise that you take the following precautions:-

- The unit is installed as instructed
- Recommended spares are kept in stock. We can assist
- Sufficient expertise available for first line maintenance
- Routine maintenance checks are performed - annually is recommended
- The necessary documentation for the product is available to the maintenance personnel

We recommend you keep on file - as a minimum

- This Manual
- The calibration figures for the attached sensors
- A record of the 'normal' output - if applicable
- A calibration record of the ICA
- A contact phone number from the supplier for assistance

Chapter 7 Glossary

AWG	American Wire Gauge
Background Noise	The total noise floor from all sources of interference in a measurement system, independent of the presence of a data signal. (See Noise)
Bipolar	The ability of a signal conditioner to display both positive and negative readings
Bridge Resistance	The resistance measured across the excitation terminals of a Strain Gauge.
Calibration	Adjustment of an instrument or compiling a deviation chart so that it's reading can be correlated to the actual value being measured
CMR (Common-Mode Rejection)	The ability of an instrument to eliminate the effect of AC or DC noise between signal and ground. Normally expressed in dB at DC to 60 Hz. One type of CMR is specified between SIG LO and PWR GND. In differential meters, a second type of CMR is specified between SIG LO and ANA GND (METER GND)
Common Mode Rejection Ratio	The ability of an instrument to reject interference from a common voltage at its input terminals with relation to ground. Usually expressed in db (decibels).
Drift	Change of a reading/set point value over periods due to several factors including change in ambient temperature, time and line voltage
Excitation	The external application of electrical voltage current applied to a transducer for normal operation
Fine Adjustment	Zero and Span calibration have a Fine Adjustment to give accuracy to the calibration. These are potentiometers P1 and P2 for Span and Zero respectively
Full Bridge	A Wheatstone Bridge configuration utilizing four active elements or Strain Gauges
Full Range Output	The algebraic difference between the minimum output and maximum output.
Gain	Gain is otherwise identified as SPAN. It relates to the proportional output to the sensor input. Calibration of the ICA is determined by setting the Gain (Span) and Offset (Zero). The amount of amplification used in an electrical circuit
Ground	The electrical neutral line having the same potential as the surrounding ground
Linearity	The closeness of a calibration curve to a specified straight line. Linearity is expressed as the maximum deviation of any calibration point on a specified straight line during any one calibration cycle
Load	The electrical demand of a process expressed as power (watts), current (amps) or resistance (ohms)
Load Impedance	The impedance presented to the output terminals of a transducer by the associated external circuitry
Load Cell	The load cell is one of a series of STRAIN GAUGE sensors that the ICA input is designed to accept. (Torque Sensor, Pressure & temperature transducers)
Millivolt	One thousandth of a volt, 10^{-3} volts symbol mV
Noise	An unwanted electrical interference on the signal wires
Null	A condition, such as balance, which results in a minimum absolute value of output
Offset	Offset is otherwise identified as ZERO. Calibration of the ICA is determined by setting the Offset (Zero) and Gain (Span)
Potentiometer	Two potentiometers (variable resistors) are used in the ICA1 & 2 for fine calibration
Pressure Transducer	The Pressure Transducer is one of a series of Strain Gauge sensors that the ICA input is designed to accept. (Torque Sensor, Load Cell and Temperature Transducers)
Proportional Outputs	The Voltage or Current outputs are calibrated to be directly proportional to the input from the sensor. The output is, within the sensor limits, taken as linear and no linearity compensation is required within the ICA
Resolution	The input corresponding to a one-unit change in the least significant digit of the data acquisition/display equipment (Good resolution is not necessarily equal to good accuracy.)

Sensing Element	That part of the Transducer, which reacts directly in response to the input
Sensitivity	This is the relationship between the change in Strain Gauge input to the level or magnitude of the output
Signal Conditioner	A circuit module that offsets attenuates, amplifies linearizes and/or filters the signal. The ICA is essentially a Signal Conditioner -more specifically known as a Strain Gauge Amplifier - in that it CONDITIONS (alters) the input signal from a load cell to an electrical output
Single Card Assembly	The ICA has only the one Printed Circuit Board assembly on which all the components are mounted. The assembly is then mounted inside an environmentally rugged enclosure
Span	Span is otherwise identified as GAIN. It relates to the proportional output to the sensor input. Calibration of the ICA is determined by setting the Span (Gain) and Zero (Offset).
Span Adjustment	The ability to adjust the gain of a process or strain meter so that a specified display span in engineering units corresponds to a specified signal span.
Stability	The quality of an instrument or sensor to maintain a consistent output when a constant input is applied
Strain Gauge	The Strain Gauge is a resistance bridge device where the bridge value alters linearly and proportionally to the force exerted on it - be it pressure, torque or load. The ICA is designed to convert this change in the of the Strain Gauge to a proportional electrical signal
Strain Gauge Amplifier	The ICA is essentially a type of Signal Conditioner that it conditions (alters) the input signal from a strain gauge to an electrical output
Torque Transducer	The Torque Transducer is one of a series of Strain Gauge sensors that the ICA input is designed to accept
Wheatstone Bridge	A network of four resistance's, an emf source, and a galvanometer connected such that when the four resistance's are matched, the galvanometer will show a zero deflection or "null" reading
Zero	Zero is otherwise identified as OFFSET. It relates to the proportional output to the sensor input. Calibration of the ICA is determined by setting the Span (Gain) and Zero (Offset)
Zero Adjustment	The ability to adjust the display of a process or strain meter so that zero on the display corresponds to a non-zero signal
Zero Offset	The difference between true Zero and an indication given by a measuring instrument. See Zero Suppression
Zero Suppression	The Span is Offset from Zero (Zero Suppressed) such that neither limit of the Span will be Zero. For example, an instrument which measures a load of a 100kg Span from 400kg to 500kg is said to have 400kg Zero Suppression
Units	
AC	Alternating Current
DC	Direct Current
Hz	Hertz (Frequency)
kHz	kilohertz (Frequency)
mA	milliamps
mm	millimetres
SC	Signal Conditioner
ICA	Strain Gauge Amplifier
V	Volts
mV	millivolt

Chapter 8 Specifications for the ICAH Range

Table 8.1 ICA1H (0.1 to 10.1 V)

Electrical and Environmental

Parameter	Minimum	Typical	Maximum	Units	Notes
Supply voltage Range	13	24	30	Volts	
Operating Current	-	8	-	mA	Note 1
Operating Temperature Range	-40	-	85	Deg C	
Storage Temperature Range	-40	-	85	Deg C	
Reverse polarity Protection	-30	-	-	Volts	

Note 1: Not including excitation current.

e.g. when connected to a 350 Ohm load cell, excitation current = $5/350 = 14$ mA

Total current = 22mA

Measurement

Parameter	Minimum	Typical	Maximum	Units	Notes
Bridge Excitation	4.90	5	5.10	Volts	
Bridge Impedance	350	1000	5000	Ohms	
Bridge Sensitivity	0.5	2.5	150	mV/V	Note 1
Output load	5000	-	-	Ohms	
Bandwidth	DC	-	1000	Hz	
'Zero' adjustment	-	±2	-	%FR	
'Span' adjustment	-	±8	-	%FR	
Linearity	-	0.02	-	%FR	
Temperature stability					
'Zero' Temperature Stability	-	0.0004	0.0015	±%FR/Deg C	At 2.5 mV/V
'Span' Temperature Stability	-	0.002	0.0051	±%FR/Deg C	At 2.5 mV/V

FR=Full Range (10 V)

Note 1: Set by calibration resistor

Table 8.2 ICA2H (0.1 to 5.1 V)

Electrical and Environmental

Parameter	Minimum	Typical	Maximum	Units	Notes
Supply voltage Range	8.5	12	28	Volts	
Operating Current	-	8	-	mA	Note 1
Operating Temperature Range	-40	-	85	Deg C	
Storage Temperature Range	-40	-	85	Deg C	
Reverse polarity Protection	-30	-	-	Volts	

Note 1: Not including excitation current.

e.g. when connected to a 350 Ohm load cell, excitation current = $5/350 = 14$ mA

Total current = 22 mA

Measurement

Parameter	Minimum	Typical	Maximum	Units	Notes
Bridge Excitation	4.90	5	5.10	Volts	
Bridge Impedance	350	1000	5000	Ohms	
Bridge Sensitivity	0.5	2.5	150	mV/V	Note 1
Output load	5000	-	-	Ohms	
Bandwidth	DC	-	1000	Hz	
'Zero' adjustment	-	±2	-	%FR	
'Span' adjustment	-	±8	-	%FR	
Linearity	-	0.02	-	%FR	
Temperature stability					
'Zero' Temperature Stability	-	0.0004	0.0015	±%FR/Deg C	At 2.5 mV/V
'Span' Temperature Stability	-	0.002	0.0051	±%FR/Deg C	At 2.5 mV/V

FR=Full Range (5 V)

Note 1: Set by calibration resistor

Table 8.3 ICA3H (± 10 V)

Electrical and Environmental

Parameter	Minimum	Typical	Maximum	Units	Notes
Supply voltage Range	± 13	± 14	± 15	Volts	
Operating Current	-	8	-	mA	Note 1
Operating Temperature Range	-40	-	85	Deg C	
Storage Temperature Range	-40	-	85	Deg C	
Reverse polarity Protection	-30	-	-	Volts	

Note 1: Not including excitation current.

e.g. when connected to a 350 Ohm load cell, excitation current = $5/350 = 14$ mA

Total current = 22 mA

Measurement

Parameter	Minimum	Typical	Maximum	Units	Notes
Bridge Excitation	4.90	5	5.10	Volts	
Bridge Impedance	350	1000	5000	Ohms	
Bridge Sensitivity	0.5	2.5	150	mV/V	Note 1
Output load	5000	-	-	Ohms	
Bandwidth	DC	-	1000	Hz	
'Zero' adjustment	-	± 2	-	%FR	
'Span' adjustment	-	± 8	-	%FR	
Linearity	-	0.02	-	%FR	
Temperature stability					
'Zero' Temperature Stability	-	0.0004	0.0015	\pm %FR/Deg C	At 2.5 mV/V
'Span' Temperature Stability	-	0.002	0.0051	\pm %FR/Deg C	At 2.5 mV/V

FR=Full Range (10 V)

Note 1: Set by calibration resistor

Table 8.4 ICA4H (4 to 20 mA)

Electrical and Environmental

Parameter	Minimum	Typical	Maximum	Units	Notes
Supply voltage Range	13	24	30	Volts	
Operating Current	-	8	-	mA	Note 1
Operating Temperature Range	-40	-	85	Deg C	
Storage Temperature Range	-40	-	85	Deg C	
Reverse polarity Protection	-30	-	-	Volts	

Note 1: Not including excitation current and output current.

e.g. when connected to a 350 Ohm load cell:-

Total current = Operating current (8 mA) + Excitation current ($5/350 = 14$ mA) + Output current (20 mA FS) = 42 mA FS (typical).

Measurement

Parameter	Minimum	Typical	Maximum	Units	Notes
Bridge Excitation	4.90	5	5.10	Volts	
Bridge Impedance	350	1000	5000	Ohms	
Bridge Sensitivity	0.5	2.5	150	mV/V	Note 1
Output load	-	-	1000	Ohms	Note 2
Bandwidth	DC	-	1000	Hz	
'Zero' adjustment	-	±2	-	%FR	
'Span' adjustment	-	±8	-	%FR	
Linearity	-	0.02	-	%FR	
Temperature stability					
'Zero' Temperature Stability	-	0.0004	0.0015	+/-%FR/Deg C	At 2.5 mV/V
'Span' Temperature Stability	-	0.002	0.0051	+/-%FR/Deg C	At 2.5 mV/V

FR=Full Range (16 mA)

Note 1: Set by calibration resistor

Note 2: 24 V minimum supply/sink mode.

Table 8.5 ICA5S (2-wire 4-20 mA)

Electrical and Environmental

Parameter	Minimum	Typical	Maximum	Units	Notes
Supply voltage Range	7.5	24	30	Volts	
Operating Temperature Range	-40	-	85	Deg C	
Storage Temperature Range	-40	-	85	Deg C	
Reverse polarity Protection	-30	-	-	Volts	

Measurement

Parameter	Minimum	Typical	Maximum	Units	Notes
Bridge Excitation	1.05	1.11	1.16	Volts	Note 1
Bridge Impedance	350	1000	5000	Ohms	
Bridge Sensitivity	0.5	2.5	55	mV/V	Note 2
Output load	-	-	800	Ohms	Note 3
Bandwidth	DC	-	1000	Hz	
'Zero' adjustment	-	±2	-	%FR	Note 4
'Span' adjustment	-	±8	-	%FR	
Linearity	-	0.02	-	%FR	
Temperature stability					
'Zero' Temperature Stability	-	0.001	0.005	+/-%FR/Deg C	At 2.5 mV/V
'Span' Temperature Stability	-	0.007	0.014	+/-%FR/Deg C	At 2.5 mV/V

FR=Full Range (16 mA)

Note 1: 1000 Ohm load cell - Typically 0.53 V for 350 Ohm cell

Note 2: Set by calibration resistor. Load cells with less than 1mV/V sensitivity are not recommended - drift and noise performance will suffer.

Note 3: 24 V supply minimum.

Note 4: 1000 Ohms load cell - change R1 to suit other load cell impedances.

Note: Recommended bridge impedance is 1,000 Ohms

Note: The voltage between either of the power supply connections and the load cell shield should not exceed 50 V. Any leakage will be greater than 10 M Ohms.

Table 8.6 ICA5A (2-wire 4-20 mA)

Electrical and Environmental

Parameter	Minimum	Typical	Maximum	Units	Notes
Supply voltage Range	9.0	24	30	Volts	
Operating Temperature Range	-40	-	85	Deg C	
Storage Temperature Range	-40	-	85	Deg C	
Reverse polarity Protection	-30	-	-	Volts	

Measurement

Parameter	Minimum	Typical	Maximum	Units	Notes
Bridge Excitation	1.05	1.11	1.16	Volts	Note 1
Bridge Impedance	350	1000	5000	Ohms	
Bridge Sensitivity	0.5	2.5	55	mV/V	Note 2
Output load	-	-	700	Ohms	Note 3
Bandwidth	DC	-	1000	Hz	
'Zero' adjustment	-	±2	-	%FR	Note 4
'Span' adjustment	-	±8	-	%FR	
Linearity	-	0.02	-	%FR	
Temperature stability					
'Zero' Temperature Stability	-	0.001	0.005	+/-%FR/Deg C	At 2.5 mV/V
'Span' Temperature Stability	-	0.007	0.014	+/-%FR/Deg C	At 2.5 mV/V

FR=Full Range (16 mA)

Note 1: 1000 Ohm load cell - Typically 0.53 V for 350 Ohm cell

Note 2: Set by calibration resistor

Note 3: 24 V supply minimum

Note 4: 1000 Ohms load cell - change R1 to suit other load cell impedances (see Chapter 3)

Note: Recommended bridge impedance is 1,000 Ohms

Note: The voltage between either of the power supply connections and the load cell shield should not exceed 50 V. Any leakage will be greater than 10 M Ohms.

Table 8.7 ICA6H (± 10 V)

Electrical and Environmental

Parameter	Minimum	Typical	Maximum	Units	Notes
Supply voltage Range	+14	+15	+27	Volts	Note 1
Operating Current	-	8	-	mA	Note 2
Operating Temperature Range	-40	-	85	Deg C	
Storage Temperature Range	-40	-	85	Deg C	
Reverse polarity Protection	-30	-	-	Volts	

Note 1: Ideally this should be limited to +15 V to +18 V for 350 Ohm load cells to minimise the on-board temperature rise thereby reducing any warm-up time.

Note 2: Not including excitation current.

e.g. when connected to a 350 Ohm load cell, excitation current = $5/350 = 14$ mA

Total current = 22 mA

Measurement

Parameter	Minimum	Typical	Maximum	Units	Notes
Bridge Excitation	4.90	5	5.10	Volts	
Bridge Impedance	350	1000	5000	Ohms	
Bridge Sensitivity	0.5	2.5	150	mV/V	Note 1
Output load	5000	-	-	Ohms	
Bandwidth	DC	-	1000	Hz	
'Zero' adjustment	-	± 2	-	%FR	
'Span' adjustment	-	± 8	-	%FR	
Linearity	-	0.02	-	%FR	
Temperature stability					
'Zero' Temperature Stability	-	0.0004	0.0015	\pm %FR/Deg C	At 2.5 mV/V
'Span' Temperature Stability	-	0.002	0.0051	\pm %FR/Deg C	At 2.5 mV/V

FR=Full Range (10 V)

Note 1: Set by calibration resistor

CE Approvals

European EMC Directive 2004/108/EC
 BS EN 61326-1:2006
 BS EN 61326-2-3:2006



In the interests of continued product development, Mantracourt Electronics Limited reserves the right to alter product specifications without prior notice.

Doc No. 517-936	Issue1.0	22.04.14
-----------------	----------	----------