

Instruction Sheet

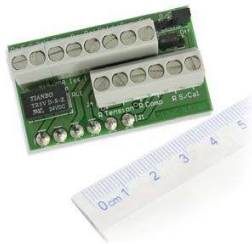

The SGABCM is a retro-fit PCB which facilitates connecting a half or quarter-bridge strain gauge to the SGA Load Cell conditioner.



SGA with a retro fitted bridge completion module pcb.

Retrofit pcb



Screw the SGABCM Module into the normal load cell connector J2

Half Bridge

The half-bridge is simply connected to the SGA via the screw terminals as shown below and no additional components are required:
Half Bridge Connection

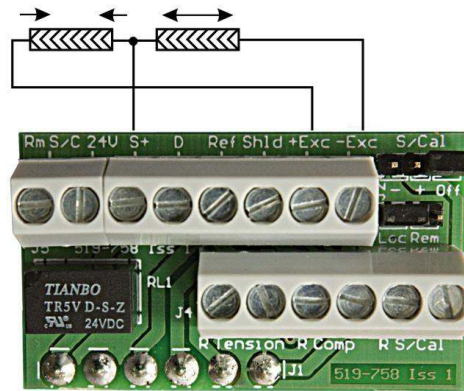

Quarter Bridge

The quarter-bridge, together with its completion resistor can be wired in two ways depending on whether the user requires a positive output as a result of the strain gauge being subjected to a compression force or a tension (stretching) force. A 350 Ohm 5ppm/°C completion resistor and a 120k 15ppm/°C shunt calibration resistor are provided in the SGABCM kit

Quarter Bridge - Compression

3-Wire Quarter Bridge - compression gives +ve output

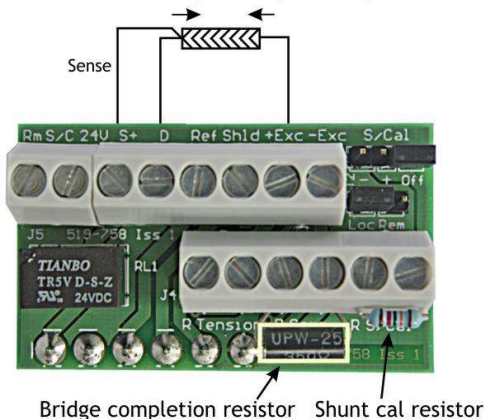

Quarter Bridge - Tension

3-Wire Quarter Bridge - tension gives +ve output

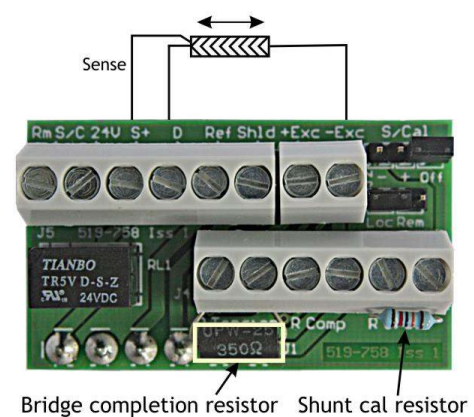

Shunt Calibration

To implement 'shunt cal' a set of header pins are provided with a jumper link that can be fitted in one of three positions: 'Off', '+' (positive shift) and '-' (negative shift). These are clearly marked on the PCB. The shorting link should be parked in the 'Off' position for normal use.

A second set of pins selects between 'Local' and 'Remote' shunt cal.

Shunt Calibration Off

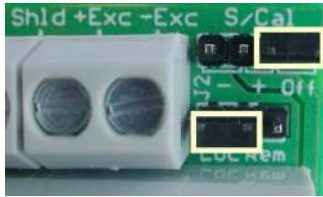

Local Positive Shunt Calibration

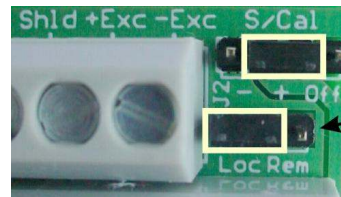

Set jumper to 'Loc'

Local Negative Shunt Calibration

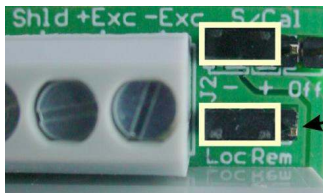

Set jumper to 'Loc'

Remote Shunt Calibration

'Remote Shunt Cal' is performed by setting the jumper to 'Rem' and energising the 24V DC relay fitted to the module.

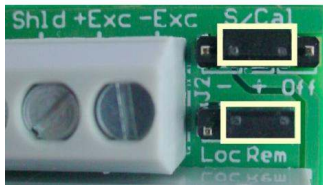

Set jumper to 'Rem'



Designed, Manufactured
& Supported in the UK



CE In the interests of continued product development, Mantracourt Electronics Limited reserves the right to alter product specifications without prior notice.